

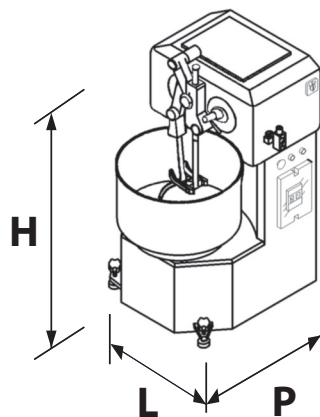

## Knetmaschine mit Taucharmen



### Tecniche Daten

Modell	Durchmesser der Zylinder $\varnothing$	Leistung kW/h	Außenabmessungen			Gewicht Kg
			L	cm P	H	
<b>ITFC/50</b> zwei Geschwindigkeiten	50	2,2 230/400 V	68	87	142	430
<b>ITFC/70</b> zwei Geschwindigkeiten	70	3,1 230/400 V	74	85	150	460