

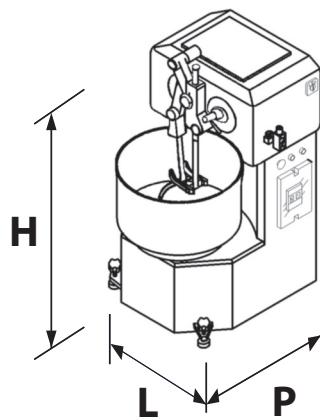

Twin arm mixer



Technical features

Model	Diameter cylinders \varnothing	Power kW/h	External Size			Weight Kg
			L	cm P	H	
ITFC/50 two speed	50	2,2 230/400 V	68	87	142	430
ITFC/70 two speed	70	3,1 230/400 V	74	85	150	460